

REVISIONS				
ZONE	REV	DESCRIPTION	DATE	APPROVED
ALL	-	ORIGINAL ISSUE	08 AUG 09	P. KOTZEBUE

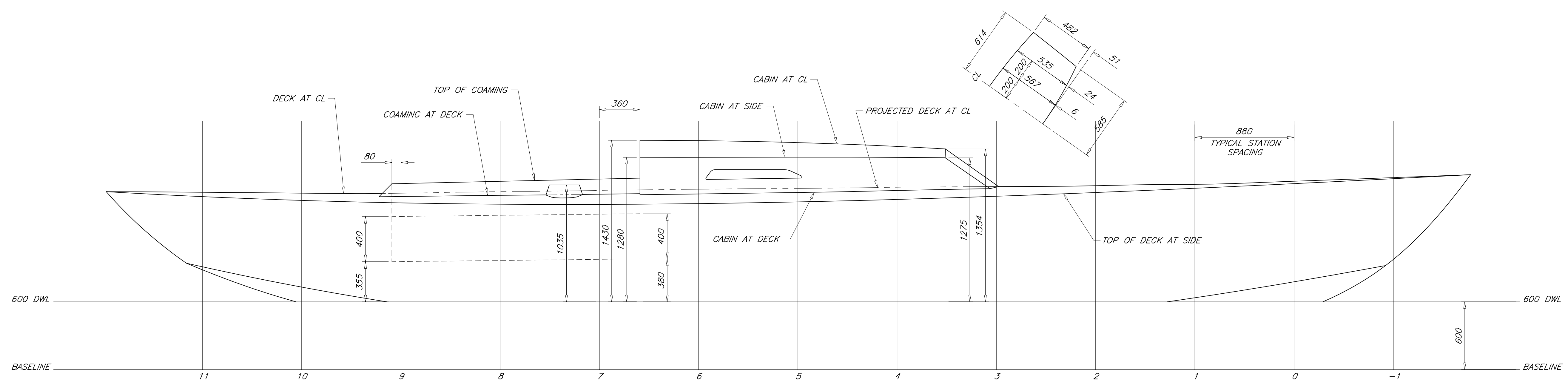

**ELEVATION C-5**  
STATION SECTIONS

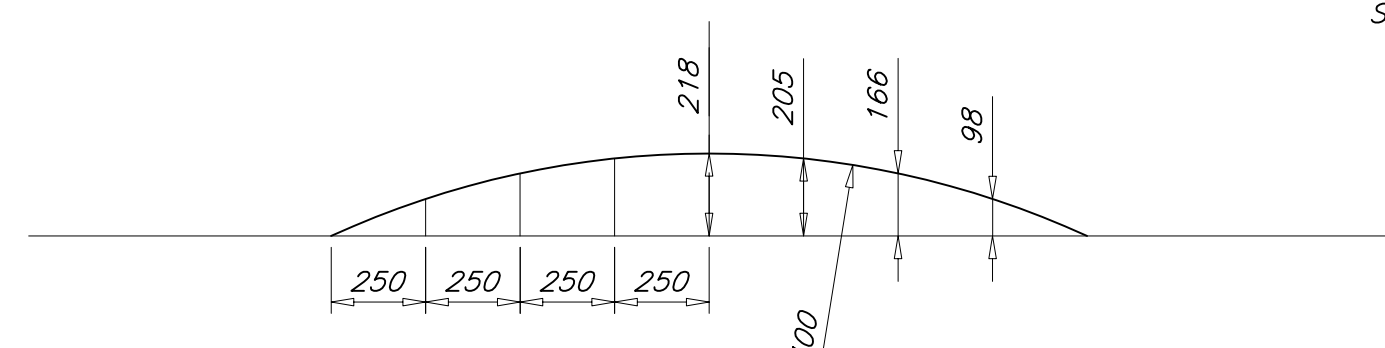

**DETAIL C-6**  
CABIN TOP CAMBER

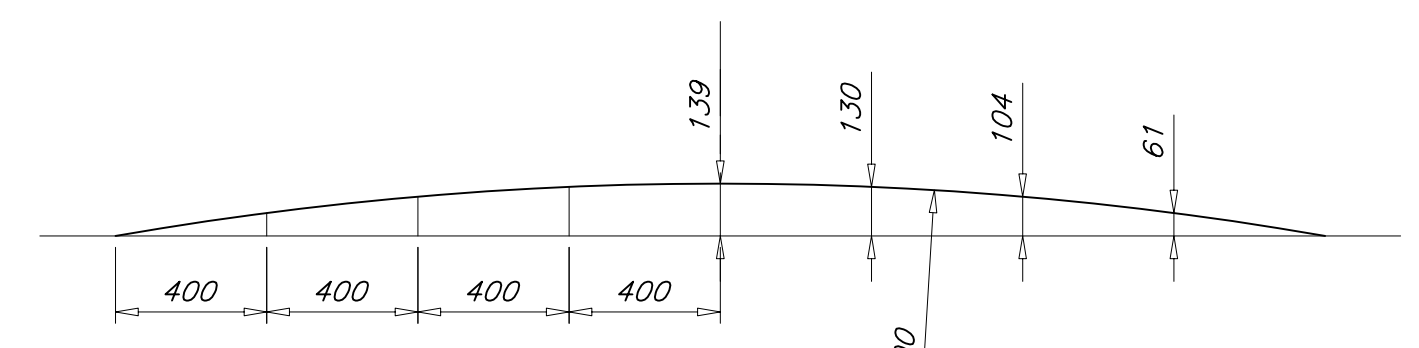

**DETAIL C-3**  
DECK CAMBER

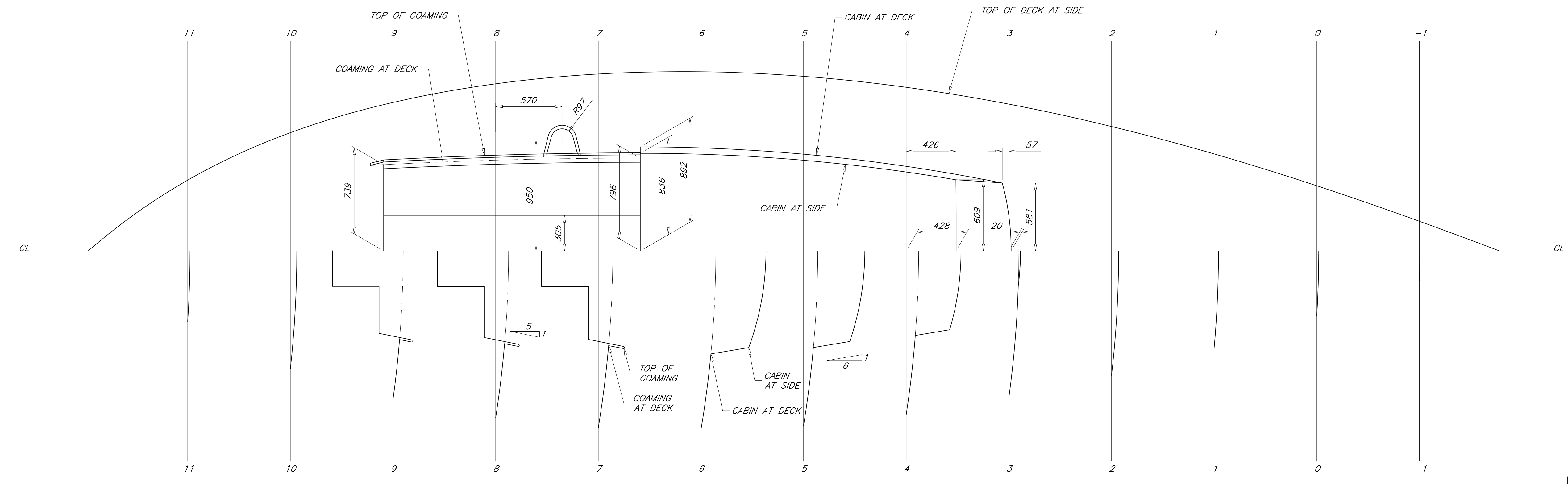

**PLAN A-5**  
STATION SECTIONS

- GENERAL NOTES**
1. ALL LINES ARE TO OUTSIDE SURFACE OF DECK, CABIN, AND COCKPIT.
  2. ALL DIMENSIONS ARE IN MILLIMETERS.
  3. SEE REFERENCE 1 FOR DECK OFFSETS.

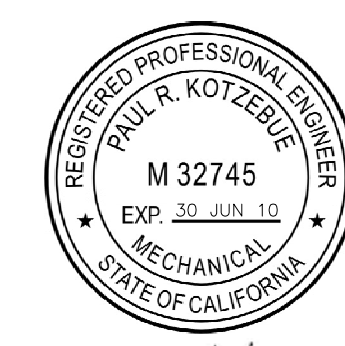

**PAUL R. KOTZEBUE, PE**  
MECHANICAL ENGINEER  
Encinitas, California USA

NO	TABLE OF OFFSETS	03-A3
	TITLE	DWG NO

REFERENCES	
STOCK PLANS	
13.5 METER PLYWOOD SLOOP	
<b>DECK LINES</b>	

DRAFTER:	PK	DATE:	08 AUG 09	SIZE:	ARCH D	DWG NO:	03-A2	REV:	-
CHECKER:	PK	DATE:	08 AUG 09	SCALE:	1 : 20	SWBS:	--	SHEET:	1 OF 1

THIS DRAWING REMAINS THE PROPERTY OF PAUL R. KOTZEBUE, PE AND MAY NOT BE USED FOR ANY PURPOSE WITHOUT WRITTEN CONSENT.